

Notice technique de montage costière de voûte

Technical instructions for the installation of the vault's upstand

Bluevoûte / Bluevoûte Therm
Bluevoûte / Bluevoûte Therm

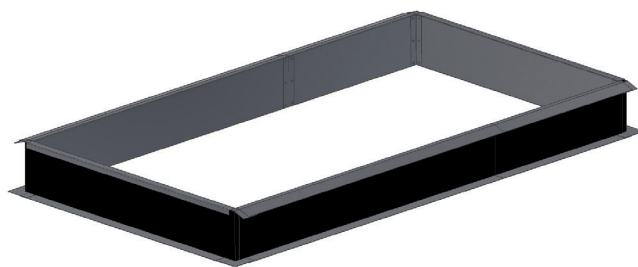

Fourniture Bluetek
Provided by Bluetek

30		31		57	
	Flancs de tympan Tympanum side of the upstand		Flancs de longpan Longside of the upstand		Vis auto-perçantes 6,3 X 19 mm Self-tapping screws 6,3 X 19 mm

Outillage à prévoir
Tools to be provided



Visseuse
Drill machine



Embout de 10 mm
Socket 10 mm

Ou
Or



Clé à pipe de 10 mm
10 mm diameter box spanner

Montage des flancs
Mounting of the sides



Pendant le montage, veiller à ce que les flancs soient perpendiculaires entre eux avant de les fixer.
During the assembly, make sure that the sides are perpendicular to each other before fixing them.

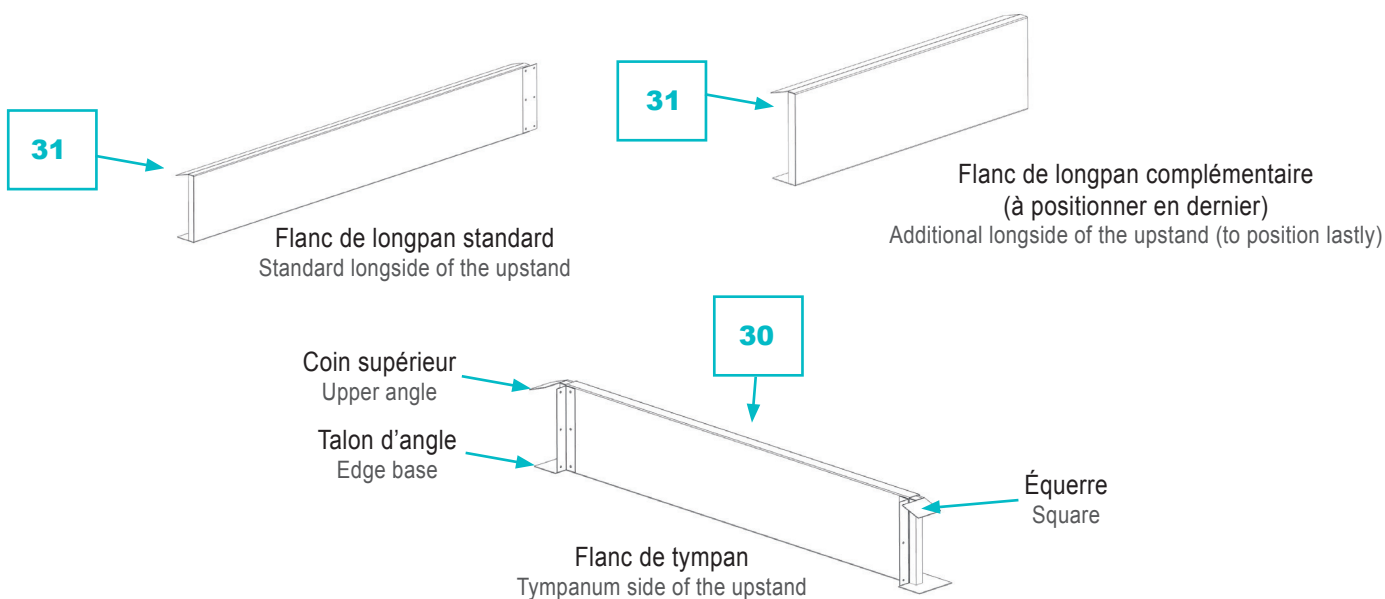
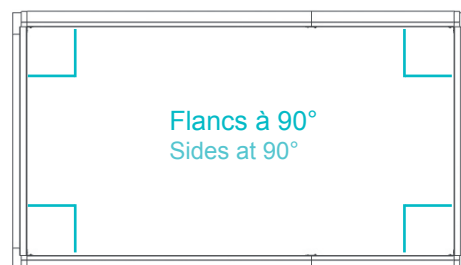

Montage des flancs longpan sur les flancs tympan

Mounting of the longsides on the tympanum sides of the upstand

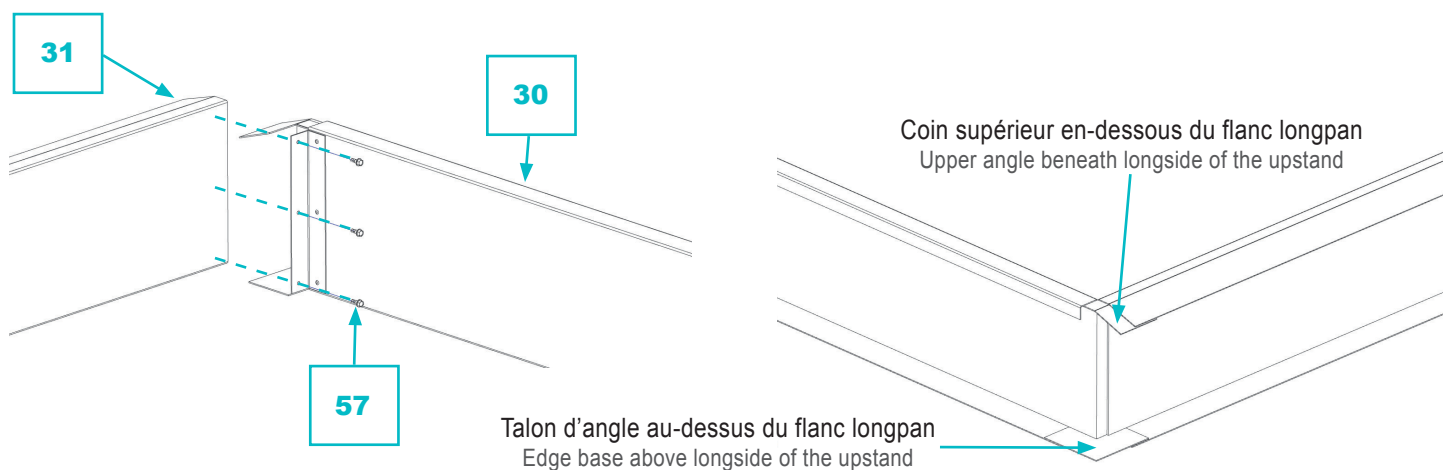

Montage de 2 flancs de costière longpan

Mounting of 2 longsides of the upstand

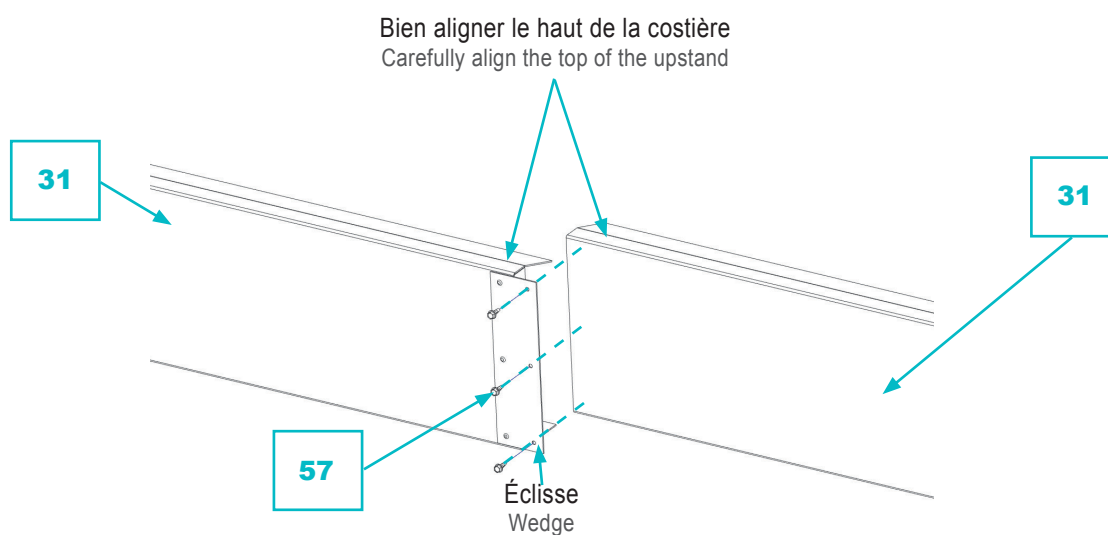

Assemblage final

Final assembly

