







# Notice technique de montage costière de voûte

## Technical instructions for the installation of the vault's upstand

**Bluevoûte RPT**  
Bluevoûte RPT



Fourniture Bluetek  
Provided by Bluetek

<b>30</b>		<b>Flancs de tympan</b> Sidewall of the upstand	<b>31</b>		<b>Flancs de longpan</b> Longside of the upstand	<b>57</b>		<b>Vis auto-perçantes</b> <b>6,3 X 19 mm</b> Self-tapping screws 6,3 X 19 mm
<b>164</b>		<b>Isolant tympan</b> Sidewall insulation	<b>165</b>		<b>Isolant longitudinal</b> Longitudinal insulation	<b>166</b>		<b>Isolant longitudinal</b> Longitudinal insulation

Outillage à prévoir  
Tools to be provided



**Visseuse**  
Drill machine

+



**Embout de 10 mm**  
Socket 10 mm

Ou  
Or



**Clé à pipe de 10 mm**  
10 mm diameter box spanner

Montage des flancs  
Mounting of the sides



Pendant le montage, veiller à ce que les flancs soient perpendiculaires entre eux avant de les fixer.  
During the assembly, make sure that the sides are perpendicular to each other before fixing them.

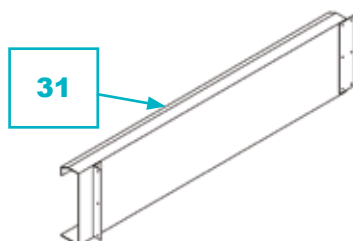
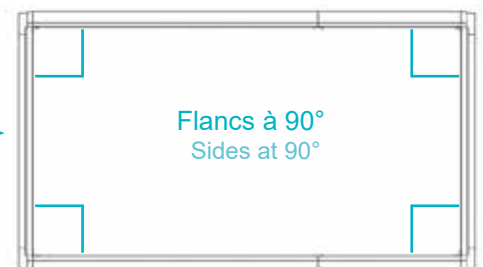

**31**  
**Flanc de longpan départ / fin**  
Departure / end longside of the upstand

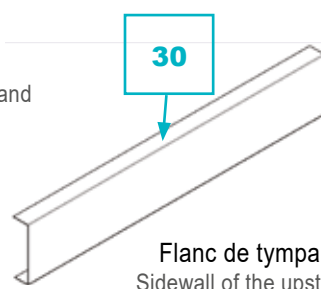

**30**  
**Flanc de tympan**  
Sidewall of the upstand

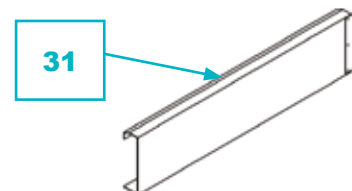

**31**  
**Flanc de longpan intermédiaire**  
Intermediate longside of the upstand

**Montage des flancs longpan sur les flancs tympan**  
Mounting of the longsidess on the sidewall of the upstand

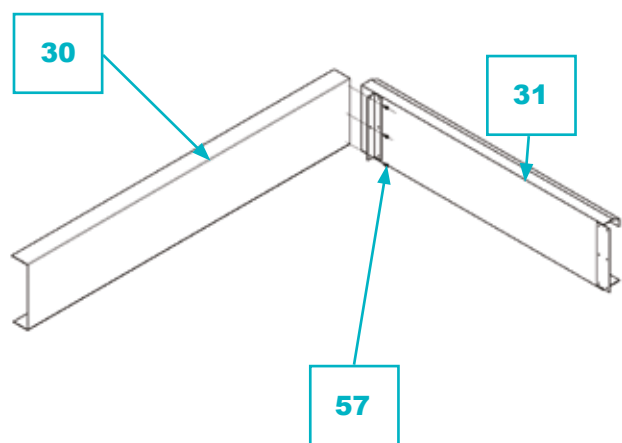

**Respecter l'alignement des hauts de costières**  
Respect the alignment of the upstand's tops

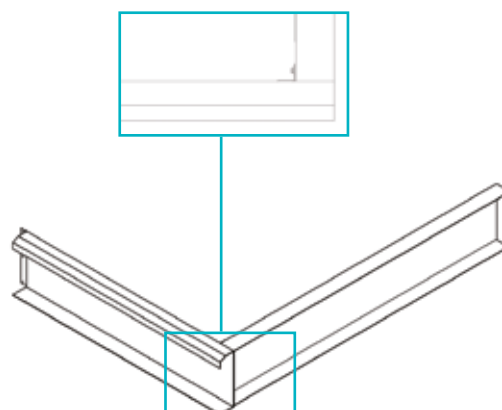

**Montage de 2 flancs de costière longpan**  
Mounting of 2 longsidess of the upstand

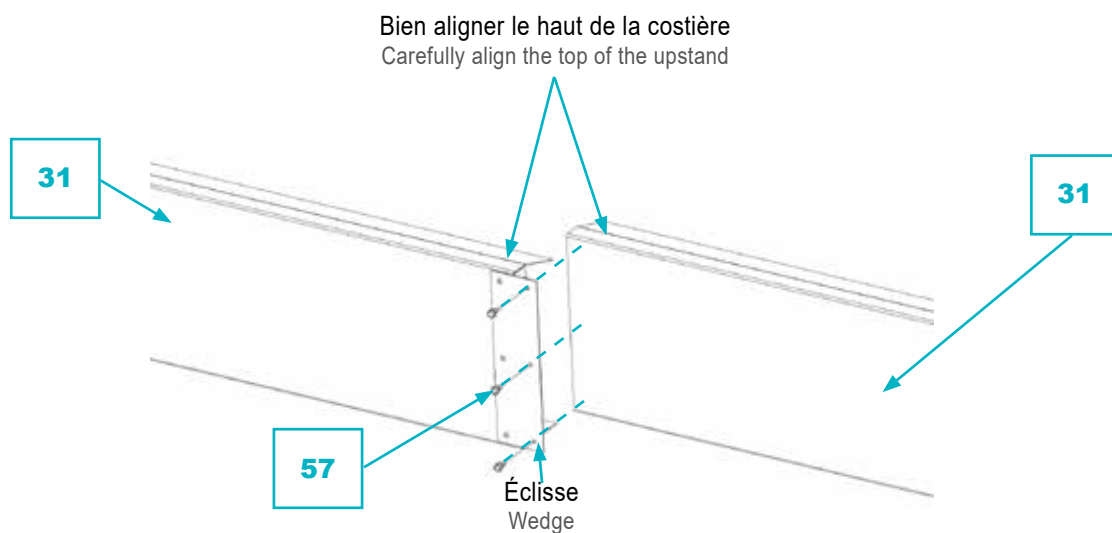

**Assemblage final**  
Final assembly

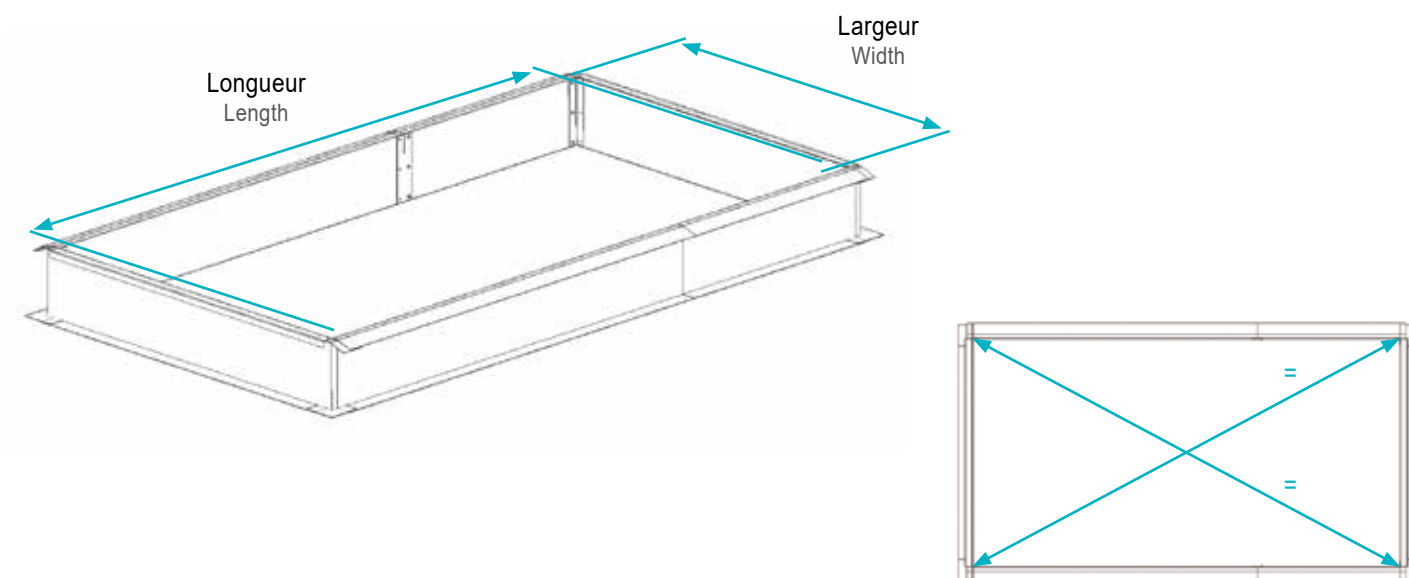

## Pose des isolants de tympan

Sidewall insulation installation

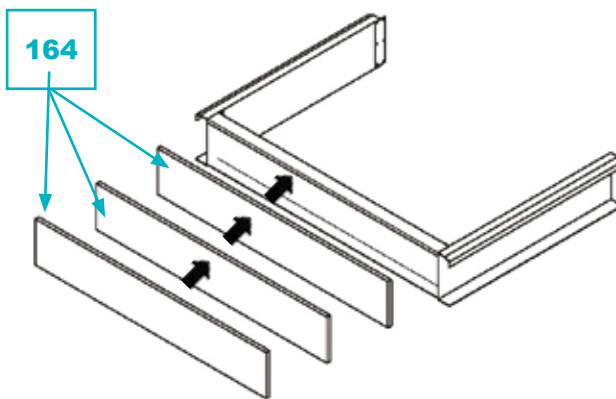
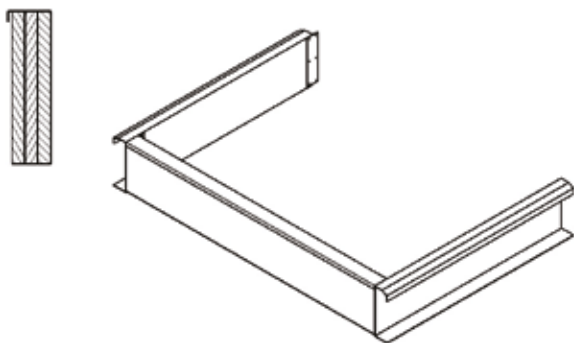

## Pose des isolants longitudinaux

Longitudinal insulation installation

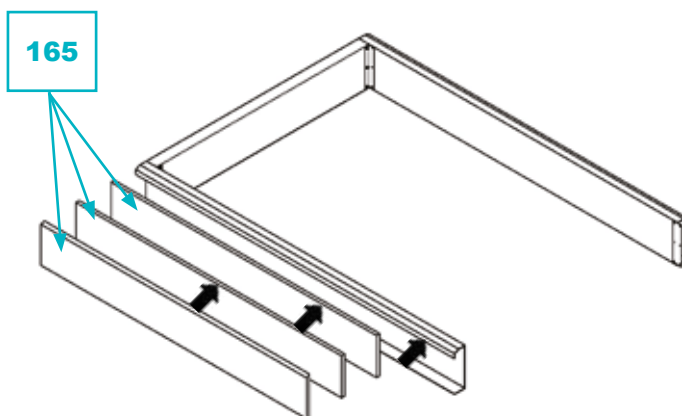
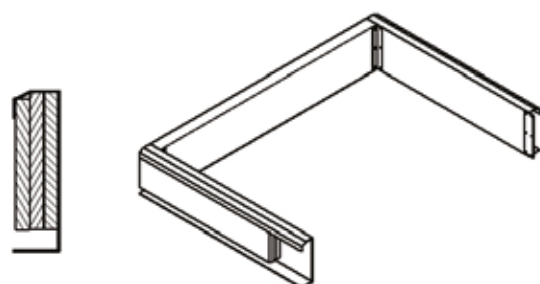

## Pose de la costière

Upstand installation

Cas de toiture plane béton ou similaire  
Case of flat concrete roof or similar

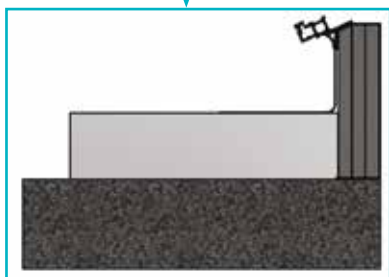

### Cas n° 1 : isolant qui descend jusqu'au talon

- Fixation de la costière sur support
- Mise en place des isolants de costière
- Mise en place de l'isolant de toiture
- Fixation de la membrane d'étanchéité
- Montage de la voûte

### Case n° 1 : Insulation which goes down to the stub

- Upstand fixation on his support
- Installation of upstand's insulation
- Installation of roof's insulation
- Fixing the waterproofing membrane
- Assembly of the vault

Cas sur chevêtre et bac (afin de respecter le DTU 43.3, la costière doit reposer sur le chevêtre et le bac sur le talon de la costière)

Case on substructure and polyester upstand (in order to respect the DTU 43.3, the upstand must to me placed on the substructure and the polyester upstand on the upstand stub)

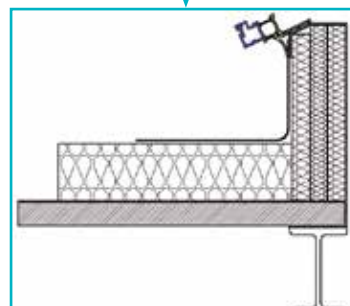

### Cas n° 2 : isolant partiel

- Fixation de la costière sur chevêtre
- Mise en place du bac
- Mise en place de l'isolant de costière
- Mise en place de l'isolant de toiture
- Fixation de la membrane d'étanchéité
- Montage de la voûte

### Case n° 2 : partial insulation

- Fixation of the upstand on his substructure
- Installation of the polyester upstand
- Installation of upstand's insulation
- Installation of roof's insulation
- Fixing the waterproofing membrane
- Assembly of the vault