

Notice technique de montage kit grille / barreaudage 1200J fixe Technical instructions for installation of kit 1200J fix grids / bars

Bluesteel / Bluecoif / Bluebac / Bluesteel Therm / Bluecoif Therm / Bluesteel RPT
 Bluesteel / Bluecoif / Bluebac / Bluesteel Therm / Bluecoif Therm / Bluesteel RPT

Fourniture Bluetek
 Provided by Bluetek

Grilles / Barreaudages
 Grids / Bars

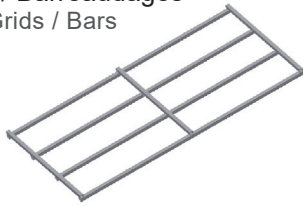
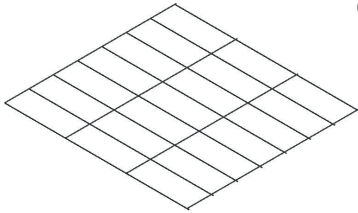

Vis 4,8 X 32 mm autoperçantes
 (pour embase polyester)
 4,8 X 32 mm self-tapping screws
 (for polyester upstand)



Vis 4,8 X 16 mm autoperçantes
 (pour costière tôle et coiffante)
 4,8 X 16 mm self-tapping screws
 (for steel upstand)



Patte de maintien
 (tous lanterneaux sauf RPT)
 Bracket
 (all skylight except RPT)



Patte de maintien
 (lanterneaux RPT)
 Bracket
 (skylight RPT)



Axe de maintien
 Holding axle



Outillage à prévoir
 Tools to be provided



Visseuse
 Screw-gun



Douille de 8 et 13 mm
 Socket 8 and 13 mm



Mètre
 Ruler

Montage
 Installation

Chaque patte de maintien est à fixer dans la costière ou l'embase, à l'aide de 2 vis autoperçantes 4,8 X 16 mm (pour costière tôle et coiffante) ou 4,8 X 32 mm (pour embase polyester)
 Each bracket is to be fixed to the upstand with 2 4,8 X 16 mm self-tapping screws (for steel upstand) or 4,8 X 32 mm (polyester upstand)

Centrer les grilles / barreaudages dans l'appareil comme indiqué
 Center grids / bars in the upstand as shown

Costière / Embase Upstand Traverse centrale Central crosstie Grille / Barreaudage Grid / Bar Patte de maintien Bracket

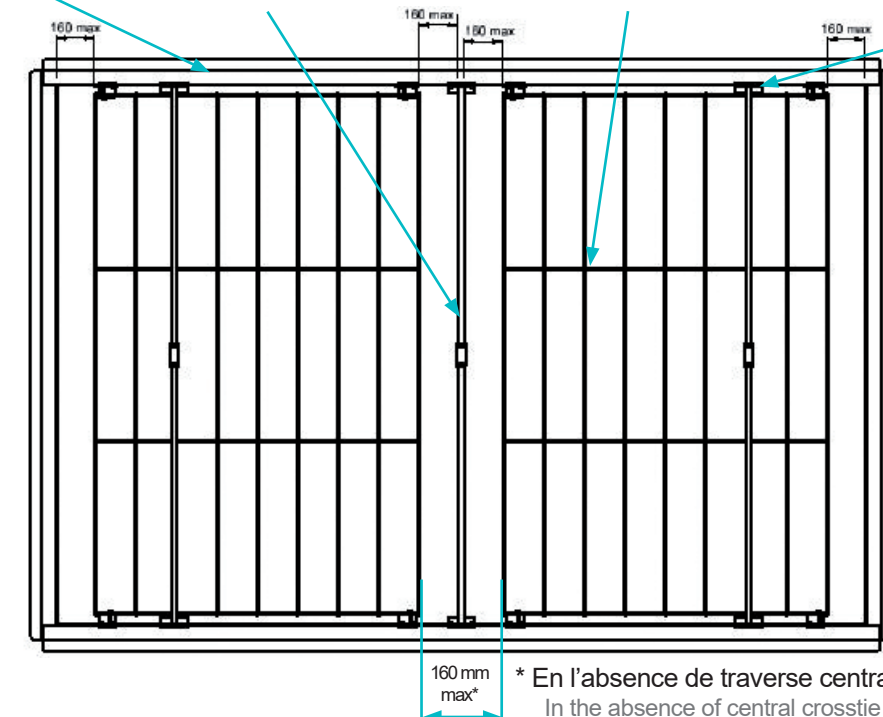

Placer les pattes de maintien contre les fils / barreaux extérieurs
Place the brackets against the exterior wire / bars

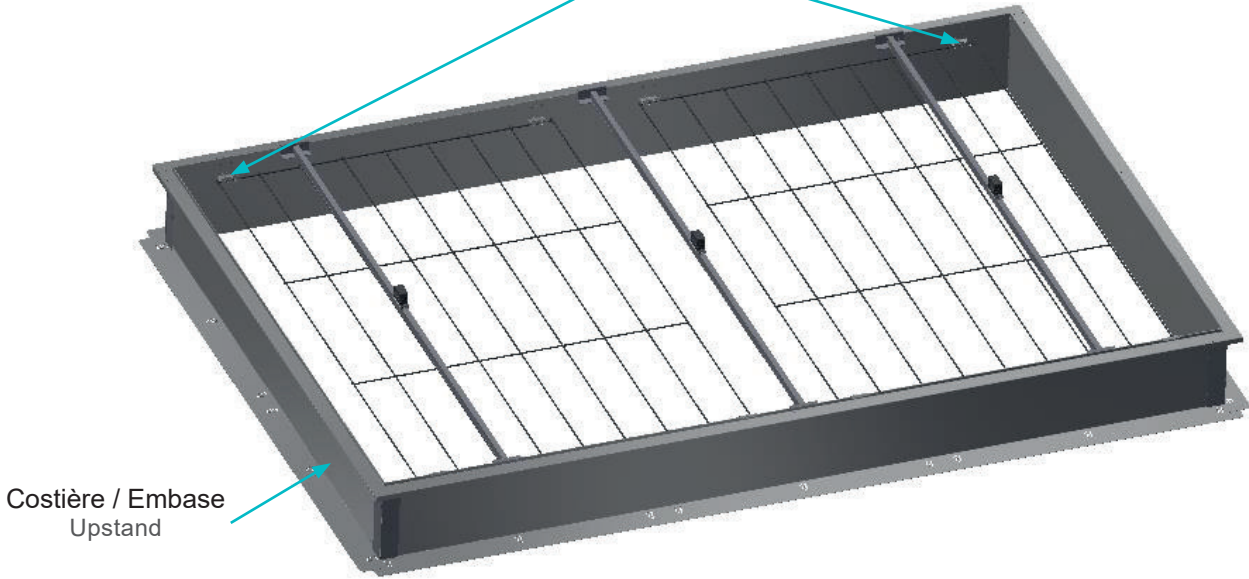

Costière / Embase
Upstand

Détail de fixation Fastening detail

Grille Grid

Vis 4,8 X 16 mm autoperçantes (X 2)
(pour costière tôle et coiffante)
4,8 X 16 mm self-tapping screws (X 2)
(for steel upstand)

Vis 4,8 X 32 mm autoperçantes (X 2)
(pour embase polyester)
4,8 X 32 mm self-tapping screws (X 2)
(for polyester upstand)

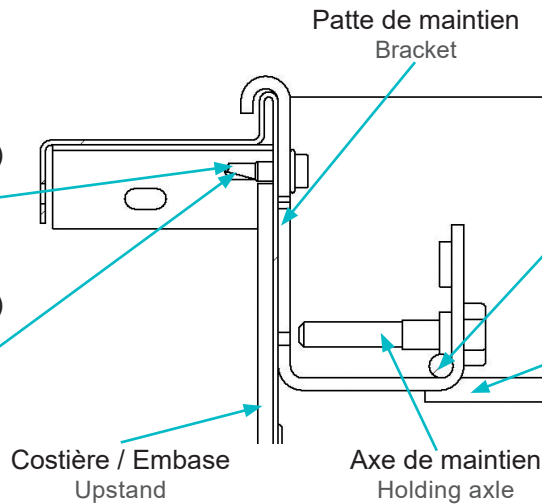

Respecter l'orientation de la grille dans l'appareil
Les fils parallèles au côté charnières sont au-dessus
Beware of the orientation of the grid into the upstand
Wire parallel to the hinges' side are above

Barreaudage Bar

Vis 4,8 X 16 mm autoperçantes (X 2)
(pour costière tôle et coiffante)
4,8 X 16 mm self-tapping screws (X 2)
(for steel upstand)

Vis 4,8 X 32 mm autoperçantes (X 2)
(pour embase polyester)
4,8 X 32 mm self-tapping screws (X 2)
(for polyester upstand)

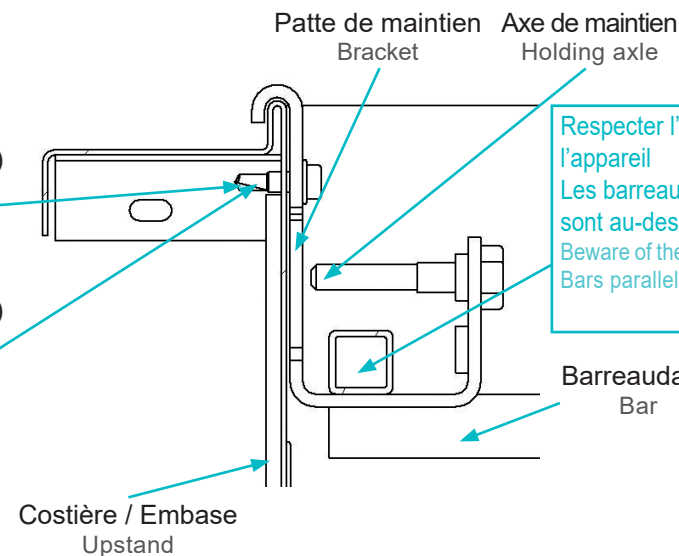

Respecter l'orientation du barreaudage dans l'appareil
Les barreaux parallèles au côté charnières sont au-dessus
Beware of the orientation of the bar into the upstand
Bars parallel to the hinges' side are above